

# Manual Plate Heat Exchanger

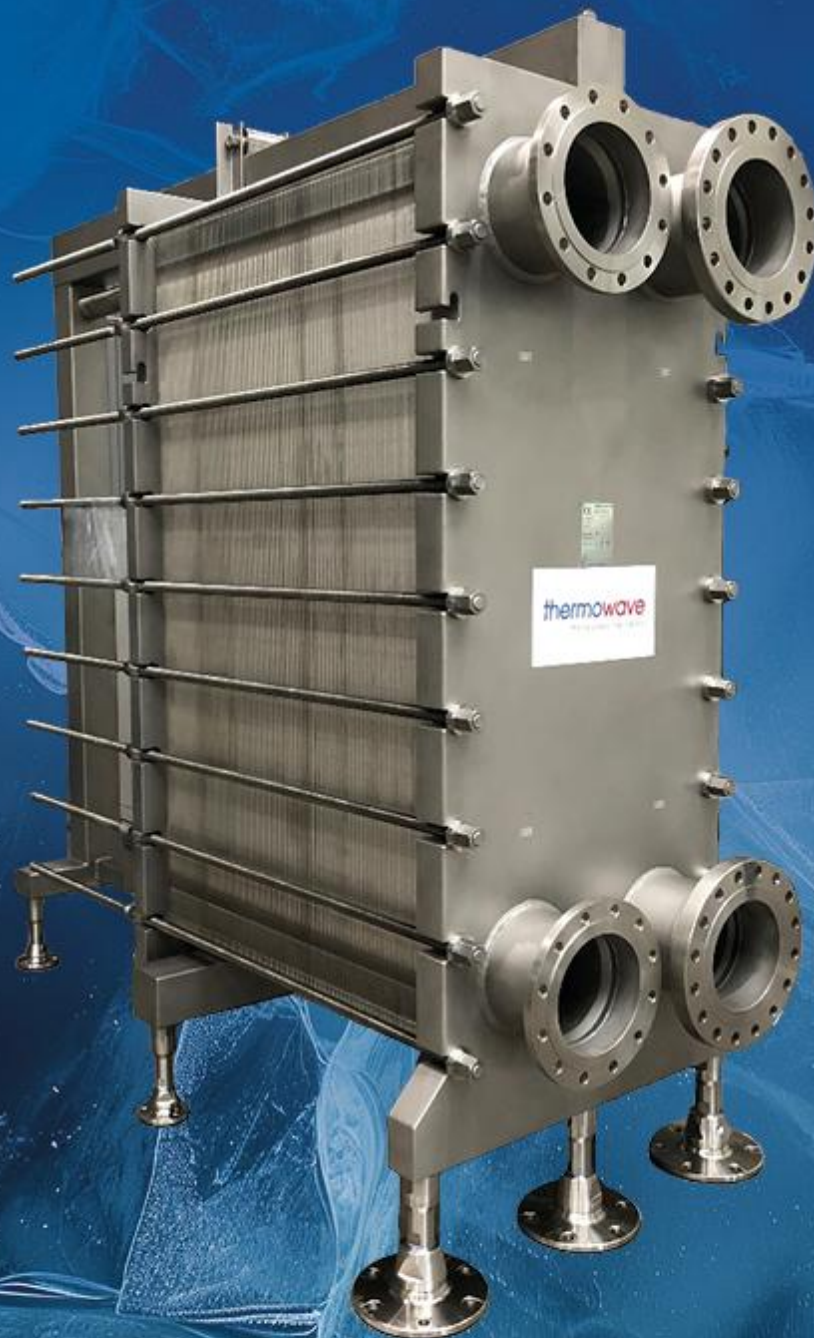

EN

FR

DE

ES

CN

PL

PT

RU

IT

Dear customer,

You have decided to purchase a quality product from thermowave GmbH.

Your plate heat exchanger represents an investment in a product that has been developed with respect to the latest research results. The individual components are in line with the latest status of the respective technology, and facilitate a high degree of functionality and reliability.

The following pages contain operating instructions for your plate heat exchanger. These operating instructions list all the important measures that will facilitate smooth operations of your plate heat exchanger. Please ensure that all persons who have anything to do with the installation, operations and maintenance of the apparatus have understood and familiarised themselves with these operating instructions.

thermowave GmbH cannot be held responsible for faults that emerge as a result of these operating instructions having been ignored. In case your plate heat exchanger encounters problems that have not been addressed in these operating instructions, we request you to promptly contact thermowave GmbH or its respective representative.

We wish you plenty of happiness with regard to the operations of your ThermoLine plate heat exchanger.

Your partner for your heat exchanger needs!

thermowave  
Gesellschaft für Wärmetechnik mbH



## Table of contents

<b>1</b>	<b>Important basic information .....</b>	<b>5</b>
1.1	Following the operating instructions.....	5
1.2	Limits of the apparatus .....	5
1.3	Technical data .....	5
1.4	Prescribed environmental conditions .....	5
1.5	Other limits.....	5
1.6	Interfaces .....	6
1.7	Responsibilities .....	6
1.7.1	The manufacturer's responsibilities .....	6
1.7.2	Responsibilities of the operator or owner .....	6
1.8	Legal information .....	7
1.9	Service address.....	7
<b>2</b>	<b>Safety.....</b>	<b>8</b>
2.1	Depiction of information.....	8
2.1.1	Warning notices .....	8
2.1.2	Further information.....	8
2.1.3	Writing styles .....	8
2.2	Diagrams and figures .....	9
2.3	Intended use of the PHE .....	9
2.3.1	Personnel requirements.....	9
2.3.2	Safety-relevant environmental conditions.....	9
2.3.3	Safety-relevant instructions for specific life phases.....	9
2.4	Possible misuse .....	10
<b>3</b>	<b>Technical data .....</b>	<b>11</b>
<b>4</b>	<b>Structure and function.....</b>	<b>12</b>
4.1	Structure.....	12
4.1.1	Main components.....	12
4.1.2	Marking on the apparatus.....	13
4.1.2.1	Sign as per PED (pressure equipment directive).....	13
4.1.2.2	Screw locking varnish .....	14
4.2	Nomenclature.....	14
4.3	Frames .....	15
4.4	Function .....	16
4.5	Heat exchanger plates and modules.....	17
4.5.1	Gasketed heat exchanger plates .....	17
4.5.2	Welded modules.....	17
<b>5</b>	<b>Delivery, transport, installation.....</b>	<b>18</b>
5.1	Delivery .....	18
5.2	Transport variants .....	18
5.3	Transport .....	18
5.4	Installing the apparatus at the installation site .....	19
5.4.1	Horizontal delivery - On the side.....	20
5.4.2	Horizontal delivery - On the head plate .....	21
5.4.3	Vertical delivery.....	22
5.4.4	Vertical delivery with base of the apparatus .....	23

<b>6</b>	<b>Connection, activation and shutdown .....</b>	<b>24</b>
6.1	Connection.....	24
6.2	Activation.....	25
6.3	Shutdown .....	26
6.4	Reactivation after shutdown .....	26
<b>7</b>	<b>Operations .....</b>	<b>27</b>
7.1	Safety.....	27
7.2	General.....	27
<b>8</b>	<b>Troubleshooting .....</b>	<b>28</b>
8.1	Safety.....	28
8.2	Service address.....	28
8.3	Performance loss .....	29
8.4	Lack of leak-tightness .....	30
<b>9</b>	<b>Maintenance, servicing and cleaning .....</b>	<b>31</b>
9.1	Safety.....	31
9.2	Service address.....	31
9.3	Maintenance schedule .....	32
9.4	Servicing work .....	32
9.4.1	Replacing the gaskets.....	32
9.4.2	Repairing leakages .....	33
9.5	Opening and closing the plate packet.....	33
9.5.1	Opening the plate packet.....	33
9.5.2	Closing the plate packet .....	34
9.6	Removal and installation of the plate packet.....	36
9.6.1	Removal of the heat exchanger plates and the modules in case of K, M, T and F (without intermediate frame) frames.....	36
9.6.2	Removal of the heat exchanger plates and the modules in case of H frame .....	36
9.6.3	Removal of the heat exchanger plates and the modules in case of N and F (with intermediate frame) frames.....	36
9.6.4	Installation of the heat exchanger plates .....	37
9.7	Cleaning .....	37
9.7.1	Cleaning the laser-welded modules .....	38
9.7.2	CIP cleaning (cleaning in place) .....	38
9.7.3	Manual cleaning.....	39
<b>10</b>	<b>Disassembly and disposal .....</b>	<b>40</b>
10.1	Disassembly.....	40
10.2	Disposal .....	40
<b>11</b>	<b>Annexe.....</b>	<b>41</b>
11.1	Parts list.....	41
11.2	Technical data sheet .....	41
11.3	Diagram .....	41
11.4	Declaration of conformity .....	41

# 1 Important basic information

## 1.1 Following the operating instructions

### NOTICE

- Please read the operating instructions thoroughly and in full.
- Ensure that the operating instructions are read and understood by all users who perform activities associated with the plate heat exchanger.
- Always store the operating instructions in a manner that ensures that they can be accessed by all users at any time.

## 1.2 Limits of the apparatus

The plate heat exchanger (PHE) is not a universal apparatus. It has been designed to be used in conjunction with specific mediums, pressures, temperatures and operating characteristics. The plate heat exchanger is a component that is meant to be firmly embedded in a system or machine. Once it has been installed, it serves to transfer heat from a heat-emitting flow medium to a heat-collecting flow medium.

### Spatial limits

The PHE must be freely accessible. Minimum distance to building parts, other machines or internal traffic routes [► chapter 11.3]. The installation of the PHE requires a stable and level surface (foundation/steel construction).

### Temporal limits

Expected service life of the PHE: In case of envisioned cycling of  $\leq 1000$  start-ups/shutdowns.

### Demarcation of work responsibilities for mounting, installation, activation:

- Activation, installation, servicing and maintenance only by skilled workers who have received instructions pertaining to the specific hazards.
- The operator should prevent the system from being accessed by unauthorised persons.

## 1.3 Technical data

Reference to the order-related technical data sheet in the annexe or, as the case may be, the name plate.

## 1.4 Prescribed environmental conditions

Risk of corrosion and contamination!

### NOTICE

- Moisture and dirt may not be allowed to penetrate the PHE.
- Protect the PHE from dust, contamination, moisture, wetness, damage and other harmful influences.
- The plate heat exchanger must be protected from the effects of weather and UV radiation.
- Do not store the PHE any longer than necessary. Store the PHE in the original packaging until it is installed.
- Until the PHE is installed, ensure that it is protected from damage and stored at a protected location that is not exposed to the effects of dust, contamination and moisture.
- Install the PHE in a manner that ensures that it is not damaged as a result of environmentally-induced hazard sources. The installation procedure should also ensure that the functioning of the apparatus is not disrupted by the actions of unauthorised entities.
- Position the PHE in a manner that ensures that it cannot be damaged by internal traffic or transportation operations.
- Facilitate optimal monitoring of the PHE and optimal accessibility of the PHE:
  - Position the PHE in a manner that ensures that it can always be monitored and checked from all sides.
  - Ensure that there is enough room for servicing activities.

## **1.5 Other limits**

After the life cycle comes to an end, it is necessary to properly dispose of the materials that have been built into the PHE [► chapter 10]. The existing standards, guidelines, laws and regulations must be complied with.

## **1.6 Interfaces**

The connections for the mediums and potential ventilation and emptying facilities can be found on one or both plates and/or on a special intermediate frame. You can find out where the connections are located on your PHE by referring to the diagram [► chapter 11]. Information regarding the type of medium, pressure, connection design and its dimensions can be found in the order-related documents [► chapter 11] or name plate.

## **1.7 Responsibilities**

### **1.7.1 The manufacturer's responsibilities**

The instructions that are contained in these operating instructions and which pertain to the preservation of the functional reliability of the PHE as well as the avoidance of potential risks during transportation, assembly, installation, activation, operations and maintenance activities (cleaning, servicing and repairs) only relate to the delivered plate heat exchanger.

### **1.7.2 Responsibilities of the operator or owner**

The responsibilities of the operator or owner are associated with the operations, servicing activities and repairs.

The operator or owner must ensure that all those who work with the apparatus have been instructed to a sufficient degree; he must also ensure that they possess the respective skills. Unauthorised persons may not be provided with direct access to the PHE.

Before the PHE is activated, the owner or operator must ensure that the respective personnel use the PHE documentation to implement the safety measures associated with the system structure, monitoring, mode of action and servicing activities; he must also ensure that the said personnel have received instructions pertaining to the respective characteristics and the handling of the mediums that are used.

When it comes to the operations, monitoring and servicing of the PHE, the operator or owner must ensure that the order-related information does not deviate from the documents.

In order to rule out secondary damage caused by faults a warning system that promptly reports all faults should be installed if necessary. The manufacturer shall assume no liability in the absence of a functioning protection mechanism.

The national and international standards, guidelines, rules and regulations applicable for the installation site, e.g. for operational safety, for recurring checks, etc. must be adhered to.

## 1.8 Legal information

Warranty claims expire:

- in situations involving faults and damages that emerge as a result of the specifications contained in these operating instructions not having been complied with,
- in case of inappropriate usage and handling of the PHE,
- in case of complaints that arise because original spare parts had not been used while replacing device parts,
- if the PHE is subjected to changes [e.g. medium, function, stress amount (initial and final amounts), operating parameters] vis-à-vis the order-related information [► chapter 11] without obtaining prior approval from the manufacturer,
- if the plate heat exchanger is opened without first consulting thermowave GmbH.

The warranty only covers the delivered plate heat exchanger;  
it does not apply to the seals that are built into it.

The operating instructions or parts thereof may not (either electronically or mechanically) be copied, distributed, modified, provided to third parties, translated or used in any other manner unless thermowave GmbH has explicitly approved of such a course of action in writing.

## 1.9 Service address

thermowave Gesellschaft für Wärmetechnik mbH  
Eichenweg 4  
06536 Berga

Tel.: +49 34651 418 9980  
Fax: +49 34651 418 9924

[service@thermowave.eu](mailto:service@thermowave.eu)

Office timings:  
Mo. - Thu. 0730 to 1600 hours  
Fr. 0730 to 1400 hours

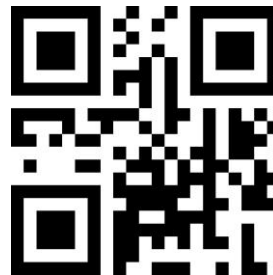

## 2 Safety

### 2.1 Depiction of information

#### 2.1.1 Warning notices

##### **DANGER**

###### **Warning against injuries resulting in death.**

Denotes an immediate and impending hazard. If such a hazard is not avoided, it results in death or the most severe injuries.

- The arrow flags a precautionary measure that must be implemented in order to avert the risk.

##### **WARNING**

###### **Warning against serious injuries.**

Denotes a hazard that could possibly be imminent. If such a hazard is not avoided, it could result in death or the most severe injuries.

- The arrow flags a precautionary measure that must be implemented in order to avert the risk.

##### **CAUTION**

###### **Warning against injuries.**

Denotes a hazard that could possibly be imminent. If such a hazard is not avoided, it could result in light or minor injuries.

- The arrow flags a precautionary measure that must be implemented in order to avert the risk.

##### **NOTICE**

###### **Warning against material damage.**

Denotes a situation that could possibly be damaging. If such a hazard is not avoided, the product or something in its vicinity could suffer damage.

- The arrow flags a precautionary measure that must be implemented in order to avert the risk.

#### 2.1.2 Further information



**TIP**  
Depiction of useful information

#### 2.1.3 Writing styles

These operating instructions make use of the following writing styles:

Writing style	Usage	Example
[Number]	Figure explanation	[1]
<b>Bold</b>	Emphasis	<b>Warning</b>
[▶ chapter number] (Figure number)	Cross-reference Figure reference	[▶ chapter 4.1.2] (Figure 28)

## 2.2 Diagrams and figures

The diagrams in these operating instructions are exemplary. Many details are depicted in a simplified manner. The binding views and dimensions of your PHE can be found in the order-related documents [► chapter 11.3].

## 2.3 Intended use of the PHE

The plate heat exchanger has been specially designed and manufactured for the operating conditions specified by you. The operating conditions have been listed on the name plate and in the technical data sheet [► chapter 11].

Deviations from these permissible operating conditions shall result in the expiry of the warranty. This also applies to situations in which important changes are independently made to the plate heat exchanger.

### 2.3.1 Personnel requirements

The PHE may only be installed, activated, operated, repaired and serviced by instructed, trained, qualified and skilled personnel. Changes involving the PHE which have been approved in advance by the manufacturer in writing may only be made by briefed or skilled personnel.

<b>⚠ CAUTION</b>	
<b>Training</b>	<b>Definition</b>
Instructed personnel	An instructed person is a person who has been briefed and (if necessary) trained with regard to the assigned tasks and the potential hazards associated with inappropriate behaviour, and who has received instructions pertaining to the required safety devices and measures.
Trained personnel	A trained person is a person who fulfils the requirements associated with an instructed person, and who has also received training.
Qualified specialist	A specialist is a person whose training, skills, experiences and knowledge of the applicable regulations enable him to evaluate the tasks assigned to him and identify potential hazards. Several years' worth of experience in the respective work area can also be considered while evaluating the technical training.
Customer service	The customer service domain consists of service technicians who have demonstrably been trained and authorised by thermowave for work pertaining to the PHE.

### 2.3.2 Safety-relevant environmental conditions

<b>NOTICE</b>
Operate the PHE in hazard-free surroundings. An aggressive atmosphere can damage the gaskets and lead to leaks. Consult thermowave if necessary.

### 2.3.3 Safety-relevant instructions for specific life phases

#### **⚠ WARNING**

##### **Transport and storage**

Crushing hazard! The PHE often has a high weight. The PHE can slip and fall away from the transport equipment. Use suitable lifting means to secure it [► chapter 5.3]. The consequences could be serious injuries, or even death. Hard impacts and shocks can damage the PHE. Position the PHE in a manner that ensures that it cannot be damaged by internal traffic and transportation operations. If the PHE is stored without any commissioning or is installed in a system with or without pressurization (e.g. as a backup or emergency/safety solution), the seals can “dry out” and lose volume.

##### **Installation and initial start-up**

If the PHE is not installed properly, there is a risk that mediums may be ejected during operations; this could lead to personal injuries and material damage.

##### **Operations**

Danger of burns and frostbite at the parts of the PHE

Risk of injury due to contact with sharp-edged parts and the plate packet; body parts can suffer serious injuries. If the PHE is put into operation spontaneously after a break it can occur leaks that recede during operation, but also destroy the seals completely, depending on the length of storage/outage.

##### **Disassembly**

The PHE may only be opened when it is at the ambient temperature and the ambient pressure. Emergent mediums can cause personal injuries.

##### **Shutdown**

The PHE should be emptied if it is to be shut down for a long time. Risk of corrosion!

### 2.4 Possible misuse

#### **NOTICE**

The plate heat exchanger is a technical tool. It has primarily been designed for steady loading.

The use of any mediums, pressures and temperatures that have not been specified is prohibited. The connection dimensions, centre of gravity and weight must be considered during installation. Use the correct connection elements to fix the PHE; use the designated attachment points.

The PHE may only be installed, activated, operated, repaired and serviced by personnel who fulfil the respective requirements [► chapter 2.3.1]. Persons who are responsible for operating, servicing, repairing and evaluating systems and their components are only considered to be skilled if they possess the training and respective expertise necessitated by their tasks.

A specialist must follow the applicable technical rules (e.g. accident prevention regulations).

### 3 Technical data

These operating instructions apply to all plate heat exchangers manufactured by thermowave. The name of your PHE can be found on its name plate – [► chapter 4.1.2].

Apparatus type	Refer to order-related documents in the annexe
ID number	Refer to order-related documents in the annexe
Order number	Refer to order-related documents in the annexe
Project number	Refer to order-related documents in the annexe
Max. permissible temperature	Refer to order-related documents in the annexe
Max. permissible pressure	Refer to order-related documents in the annexe
Volume	Refer to order-related documents in the annexe
Test pressure	Refer to order-related documents in the annexe
Weight	Refer to order-related documents in the annexe

## 4 Structure and function

### 4.1 Structure

#### 4.1.1 Main components

The following section depicts the main components and the fundamental structure.

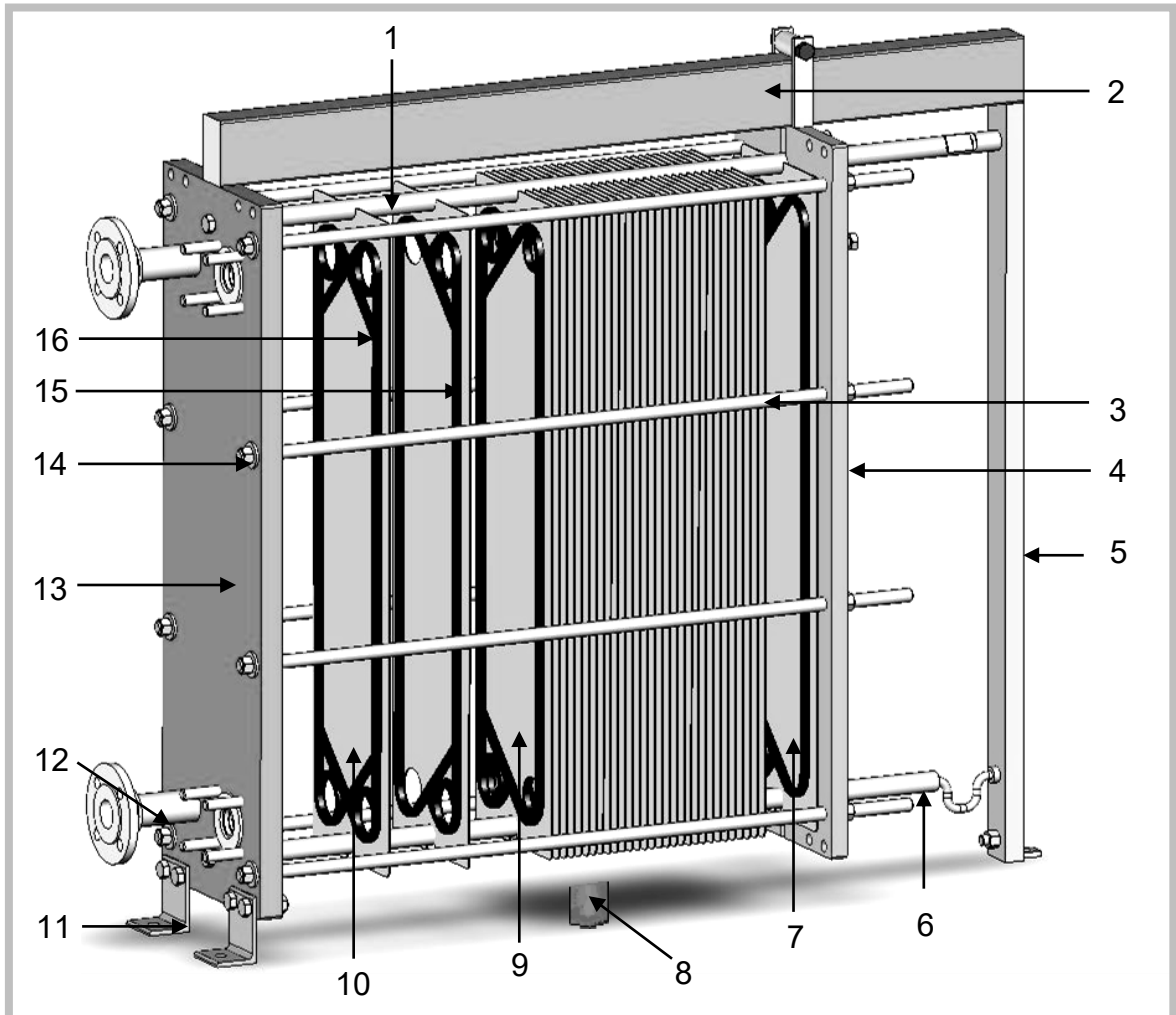

Figure 1: Overview of the PHE

#### Apparatus part no.

1. Upper support rod
2. Profile support rod (optional)
3. Threaded rod
4. Frame cover
5. Support
6. Lower support rod
7. End plate
8. Support foot (optional)

#### Apparatus part no.

9. Heat exchanger plate
10. Initial plate
11. Support angle
12. Connections
13. Frame head
14. Nut
15. Gasket (2 rings)
16. Initial Gasket (4 rings)

#### 4.1.2 Marking on the apparatus

##### 4.1.2.1 Sign as per PED (pressure equipment directive)

The head plate of every single PHE is equipped with a name plate. It provides important information such as:

- Identification number of the specified spot
- Apparatus type
- ID number/Year of manufacture
- Tensioning dimension (initial/final dimension)
- Empty weight
- Category as per PED
- Space
- Medium
- Volume
- Permissible pressure
- Permissible temperature

Additional information is provided in the name plate depending on the order.

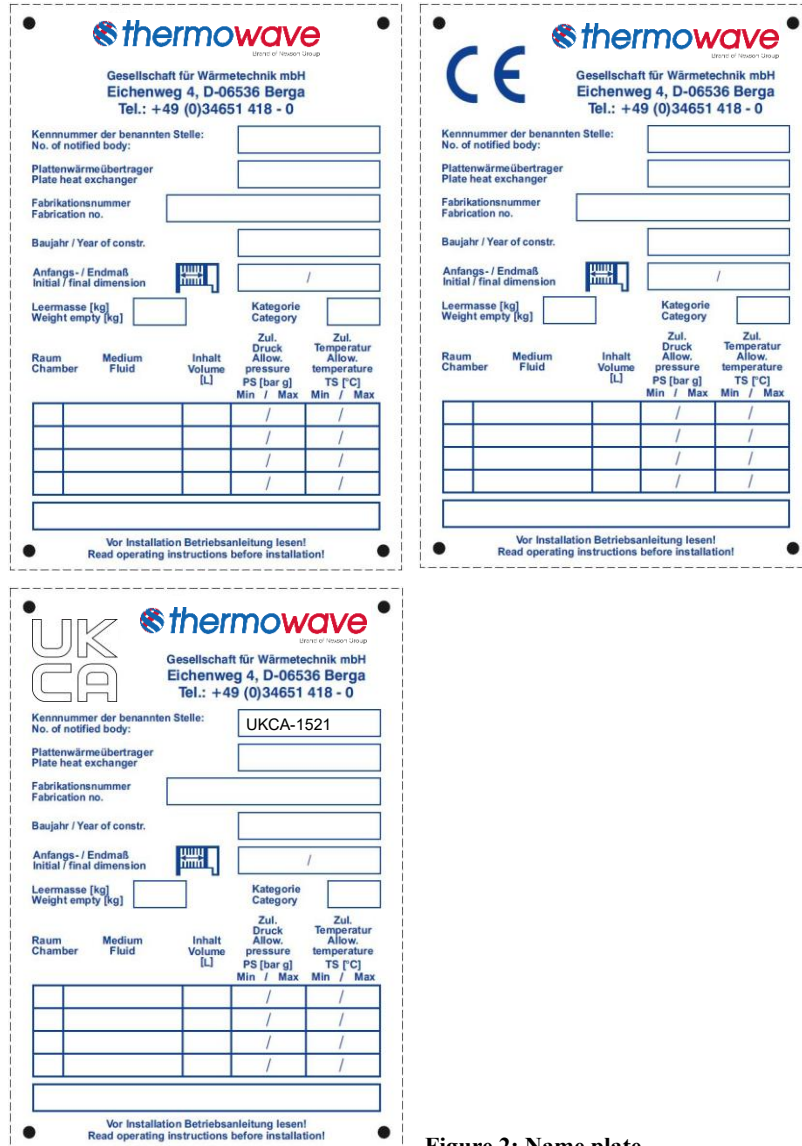

**thermowave**  
Brand of Nexson Group

Gesellschaft für Wärmetechnik mbH  
Eichenweg 4, D-06536 Berga  
Tel.: +49 (0)34651 418 - 0

Kennnummer der benannten Stelle:  
No. of notified body:

Plattenwärmeübertrager  
Plate heat exchanger

Fabrikationsnummer  
Fabrication no.

Baujahr / Year of constr.

Anfangs- / Endmaß  
Initial / final dimension  /

Leermasse [kg]  
Weight empty [kg]

Kategorie  
Category

Raum Chamber	Medium Fluid	Inhalt Volume [L]	Zul. Druck Allow. pressure PS [bar g]	Zul. Temperatur Allow. temperature TS [°C]
			Min / Max	Min / Max

Vor Installation Betriebsanleitung lesen!  
Read operating instructions before installation!

**UKCA** **thermowave**  
Brand of Nexson Group

Gesellschaft für Wärmetechnik mbH  
Eichenweg 4, D-06536 Berga  
Tel.: +49 (0)34651 418 - 0

Kennnummer der benannten Stelle:  
No. of notified body:

Plattenwärmeübertrager  
Plate heat exchanger

Fabrikationsnummer  
Fabrication no.

Baujahr / Year of constr.

Anfangs- / Endmaß  
Initial / final dimension  /

Leermasse [kg]  
Weight empty [kg]

Kategorie  
Category

Raum Chamber	Medium Fluid	Inhalt Volume [L]	Zul. Druck Allow. pressure PS [bar g]	Zul. Temperatur Allow. temperature TS [°C]
			Min / Max	Min / Max

Vor Installation Betriebsanleitung lesen!  
Read operating instructions before installation!

Figure 2: Name plate

The medium signs can be found at the connections; they denote the entry and exit of the mediums.



Figure 3: Medium sign

#### 4.1.2.2 Screw locking varnish

Screw locking varnish can be found on two of the tensioning screws on the frame cover (Figure 4). The varnish primarily serves to ensure that the tensioning screws are sealed at delivery.

**NOTICE**

The position of the screw locking varnish depends upon the size of the PHE.

- Follow the instructions given in chapter 5 “Delivery, transport, establishment”.
- The manufacturer should be informed before the screw locking varnish is broken.

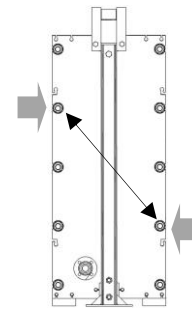

Figure 4

#### 4.2 Nomenclature

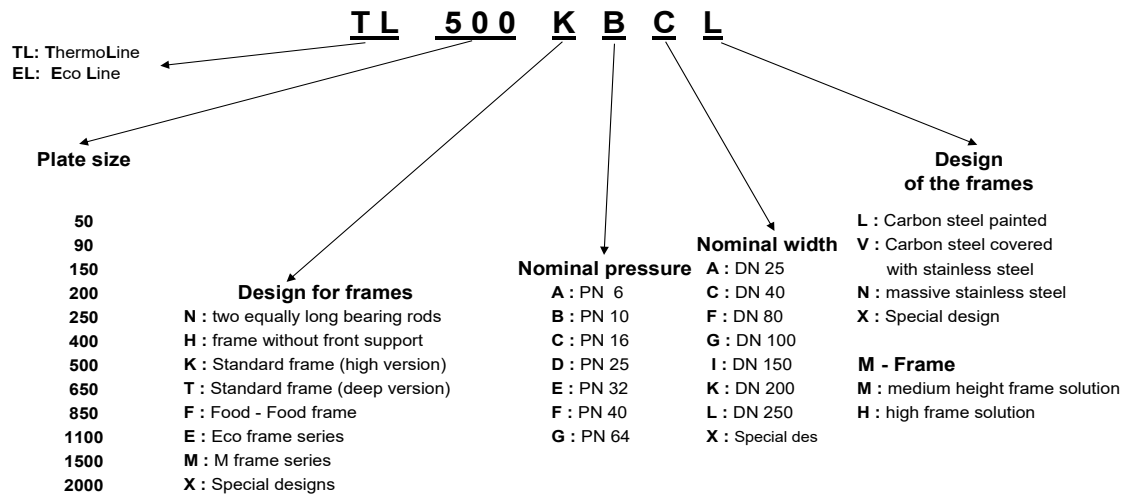
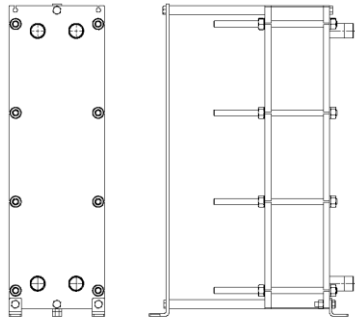

Figure 5

### 4.3 Frames

The plate heat exchanger is available in conjunction with various frame designs. Along with the maintenance-friendly and optimised K and N frame models, a frame type featuring a very low design height (model T) is also available. Apparatus types TL 50/TL 90/TL 150 (which have a low number of heat exchanger plates) are also produced, along with a frame type that does not have a rear-side support (model H).

Special variants of stainless steel are used in all processes pertaining to the cooling and heating operations associated with the food and beverage sector.



**Figure 6: Eco frame**

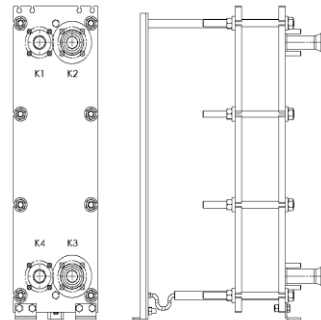

**Figure 7: M-frame**

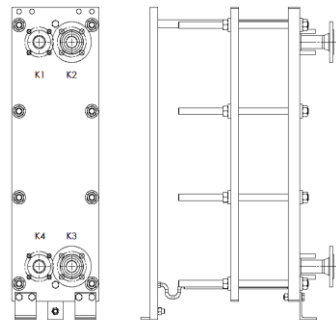

**Figure 8: K-frame**

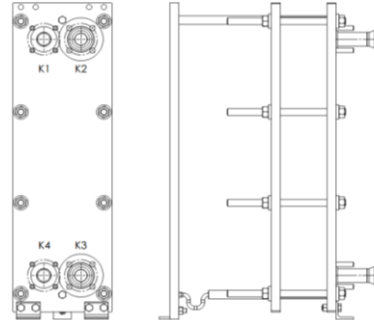

**Figure 9: T-frame**

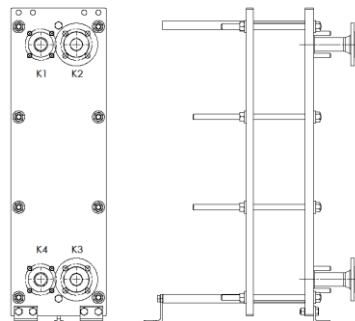

**Figure 10: H-frame**

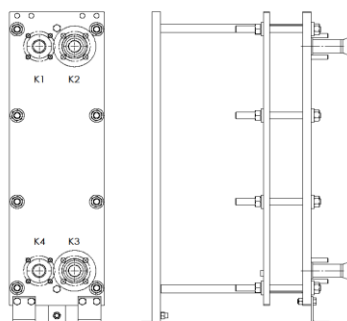

**Figure 11: N-frame**

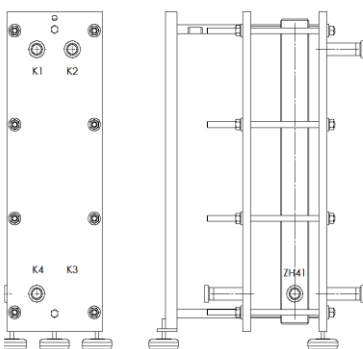

**Figure 12: F-frame with intermediate frame**

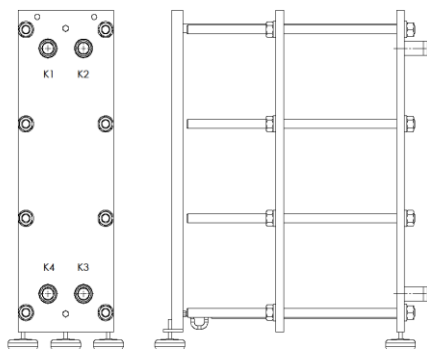

**Figure 13: F-frame without intermediate frame**

#### 4.4 Function

The PHE consists of shaped heat exchanger plates featuring installed gaskets, which are clamped together (such that they remain detachable) between a stationary and moving pressure plate with the help of tensioning screws, and which are arranged between the upper and lower support rods. Plates featuring gaskets and welded modules featuring various stampings are available for the most diverse application areas. The mediums can be guided along the counter-current and co-current flows in a use-oriented manner. Medium-resistant, temperature-resistant and adhesive-free gaskets are used in accordance with the operating conditions. Connections at the frame plate and/or cover plate are used to guide the mediums that participate in the heat transfer process into the plate packet. The parallel arrangement of the plates gives rise to channels that can be used to distribute the mediums into the plate gap and remove them from the heat exchanger. Plates with different duct cross-sections and stamping structures can be combined with each other such that the available pressure differences are used optimally for heat transport on account of the emergence of turbulence (Figure 14, 15, 16). The mediums can be redirected by installing switch plates; in such a case, the mediums can participate in the heat transfer process repeatedly, at a higher speed and for a longer period of time (Figure 17, 18). High NTU values can thus be attained within a very compact apparatus; it also becomes possible to make use of minor temperature differences between the cold and warm mediums. NTU stands for 'number of transfer units'; it is a measure of the performance of a plate heat exchanger for a simple pass.

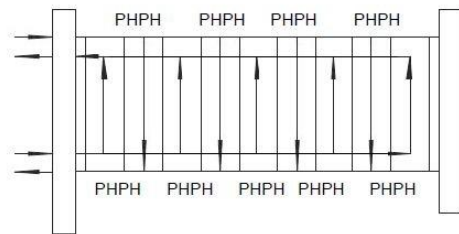

**Figure 14: Single-start circuit with identical duct cross-section (P) made of plates with the same stamping (H)**

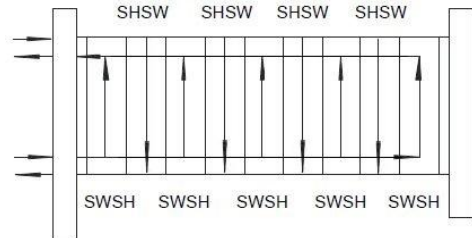

**Figure 15: Single-start circuit with identical duct cross-section (S) made of plates with different stamping (H + W)**

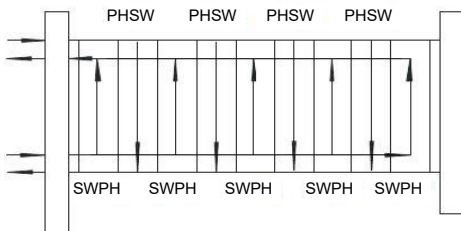

**Figure 16: Single-start circuit with various duct cross-sections (P + S) from plates with different stamping (H + W)**

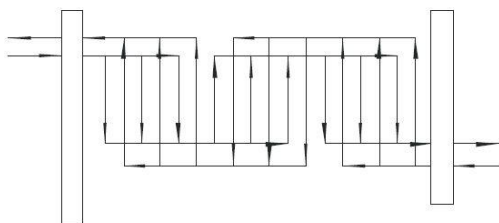

**Figure 17: Multi-start circuit – Same no. of gears on primary and secondary sides**

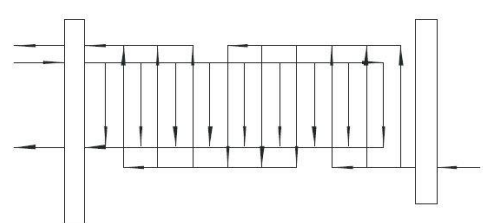

**Figure 18: Multi-start circuit – Different no. of gears on primary and secondary sides**

## 4.5 Heat exchanger plates and modules

### 4.5.1 Gasketed heat exchanger plates

All thermoline plate heat exchangers are available with gasketed plates. The advantage of using gasketed plates is that after the plate packet has been opened, all the flow channels are directly accessible for the purposes of inspection. The individual plates can be cleaned while they are hanging in the frame; if necessary, they can be removed and subjected to a special cleaning procedure.

Another advantage lies in the fact that the PHE can easily and flexibly be adapted to new usage conditions by changing the number of plates and/or the circuit of the plate packet, and by installing plates with a different stamping structure.

### 4.5.2 Welded modules

A laser system is used to weld two heat transfer plates into a gas-tight module. This gives rise to a hermetically gasketed (towards the outside) flow passage, into which the aggressive or critical (for the gasket) medium flows. Two ring gaskets made of special highly-resistant materials which guarantee the transition from one module to the next are the only gaskets that come into contact with the aggressive medium. The flow space is gasketed for the less critical medium with the help of gaskets made of the usual elastomers, which are specified for the specific application case in question. The gaskets are attached without using adhesives.

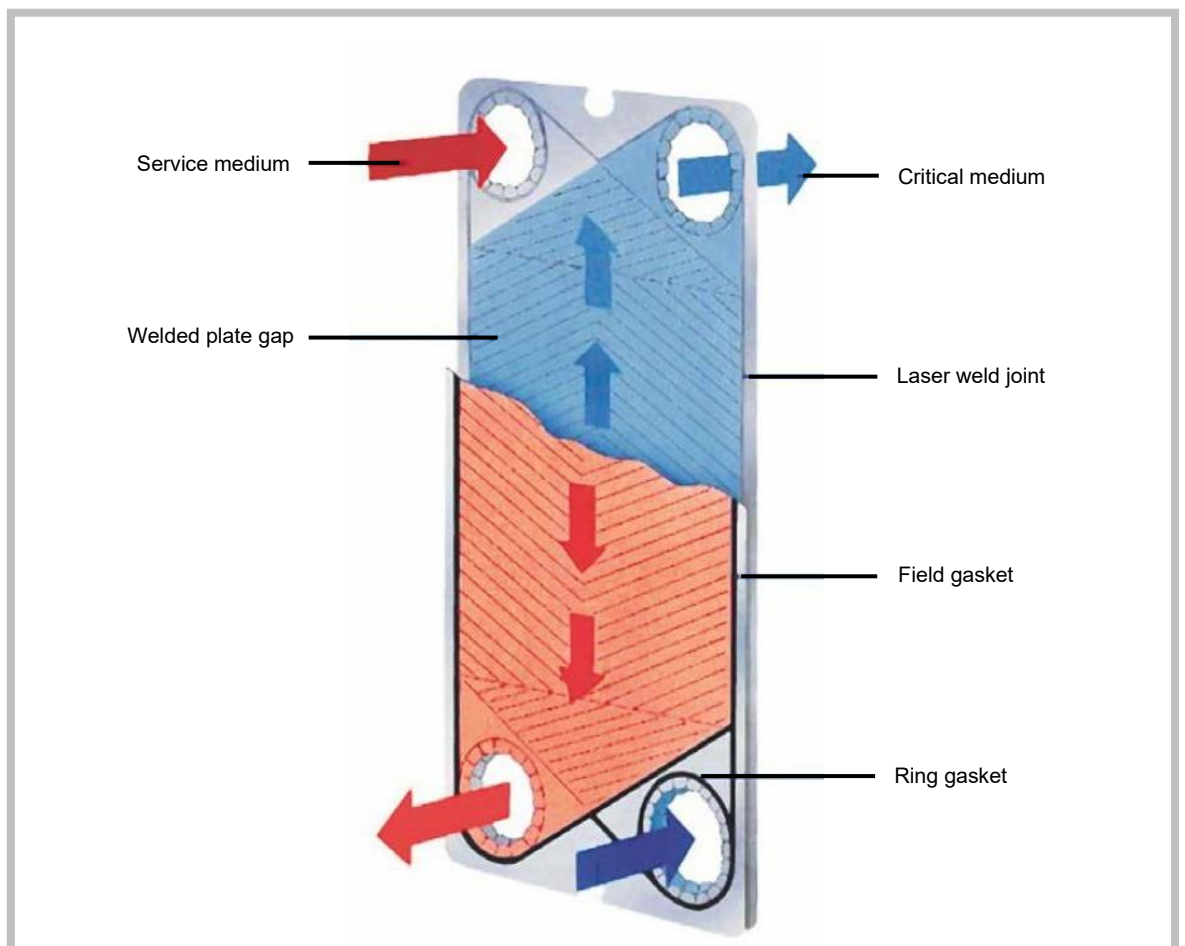

Figure 19: Welded module

## 5 Delivery, transport, installation

### 5.1 Delivery

If you notice damage at the time of delivery, please use the freight documents to note down the scope and type of damage, and get it documented by the deliverer.

Please check whether your delivery is complete.

Please raise prompt complaints regarding missing or damaged parts by contacting the following address:

thermowave Gesellschaft für Wärmetechnik mbH  
Eichenweg 4  
06536 Berga

Tel.: +49 34651 418 9980

Fax: +49 34651 418 9924

service@thermowave.eu

Office timings:

Mo. - Thu. 0730 to 1600 hours

Fr. 0730 to 1400 hours



### 5.2 Transport variants

Depending on the frame size, the PHE is delivered in a horizontal or vertical condition. The connections for pipes are sealed with transport plugs.

- PWÜs that are delivered in a horizontal condition are packaged and fastened on pallets in a manner that ensures that they remain safe during transport.
- PWÜs that are delivered in a vertical condition are secured on the truck using transport belts.

### 5.3 Transport

#### **⚠ DANGER**

#### **Mortal danger due to the use of the wrong lifting means**

- Do not use any steel ropes or chains.
- Only use undamaged round slings.
- Attach shackles or round slings to the suspension eyes, or attach the bores to the frame head and/or frame cover.



Chain



Steel rope



Shackle

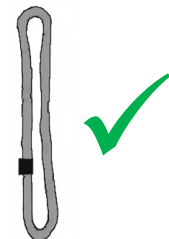

Round sling

**⚠ WARNING**

**Mortal danger due to high dead weight of the PHE**

The PHE can tip over or fall down when it is being transported using a ground conveyor or crane. This can lead to life-threatening accidents.

- If possible, ensure that a horizontal PHE is erected for the first time at the installation site.
- A PHE that has been delivered in the vertical condition must be transported to the installation site in a suspended state (Figure 21).
- Use a suitable transport device (ground conveyor, crane with sufficient load-bearing capacity) to transport the packaged PHE to the final installation site.
- Under no circumstances may tensioning screws, connections or intermediate frames be used to attach the lifting means.
- Ensure that nobody is beneath the PHE or near the danger zone during transport.
- Direct dead shoring operations without pallets may not be carried out, either in the longitudinal or transverse direction (Figure 20).
- The supporting surface of the ground conveyor must be long enough to ensure that the pallet does not get ruptured.
- The PHE should not be positioned in place in a forceful manner.

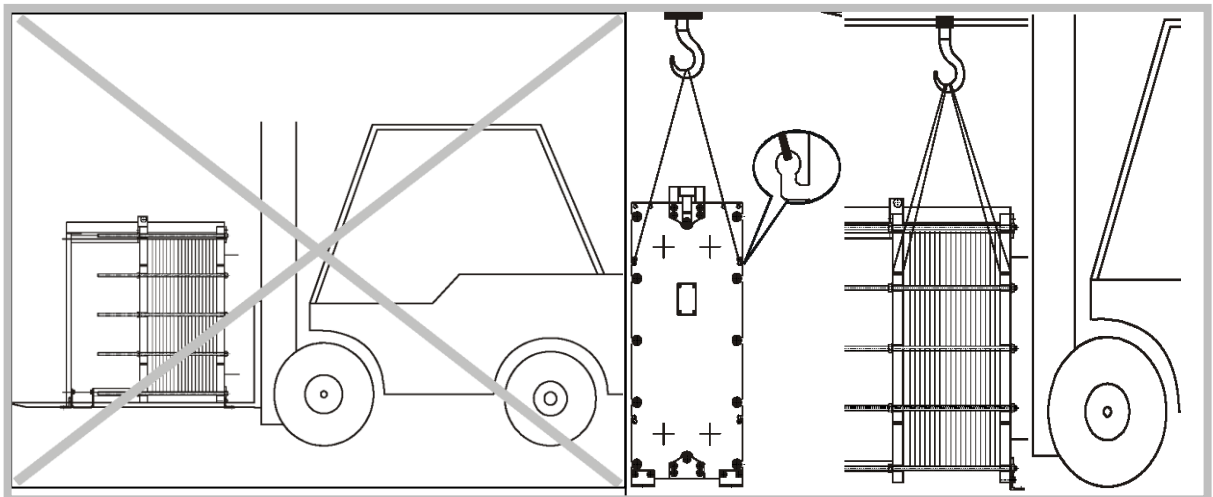

Figure 20

Figure 21

**5.4 Installing the apparatus at the installation site**

**⚠ WARNING**

**Risk of injury while erecting due to lack of stability and height vis-à-vis the ground.**

The PHE can tip over or fall down when it is being erected using a ground conveyor or crane. This can lead to life-threatening accidents.

- Wear a safety helmet and safety clothing
- Use suitable lifting means and the available suspension eyes for lifting.
- Do not lower and erect the system in a jerky manner.

### 5.4.1 Horizontal delivery - On the side

**⚠ DANGER**

**Mortal danger due to tipping over of the PHE**

The PHE can tip over due to its high dead weight.

- Anchor or bolt the PHE firmly at the installation site before you undo the lifting means.

Follow the following instructions:

1. Detach the conveyor belts from the PHE and the pallet.
2. Attach suitable lifting means to the designated suspension eyes of the frame plates (Figure 22). Chain suspensions may not be used. The PHE can be damaged and slip off.
3. Slowly lift the PHE off the pallet with the help of the centre of gravity (Figure 23). Ensure that the lifting means are firm and secure within the suspension eyes.
4. Carefully lower the PHE onto the base of the apparatus (Figure 24).
5. Align the PHE in the desired position and bolt the bases of the apparatus to the floor.
6. Remove the lifting means.
7. Use the order-related documents or the information specified on the name plate to check the tensioning dimension. If these values are not in line with each other, contact thermowave's customer service department.
8. Check whether the screw locking varnish is ruptured [► chapter 4.1.2.2]. In case of damage, contact thermowave's customer service department.

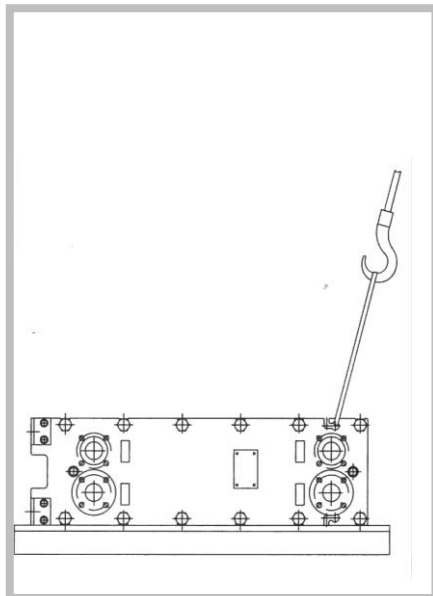

Figure 22

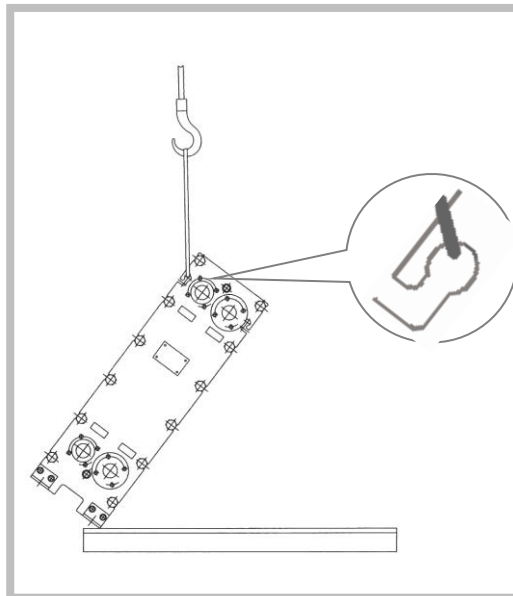

Figure 23

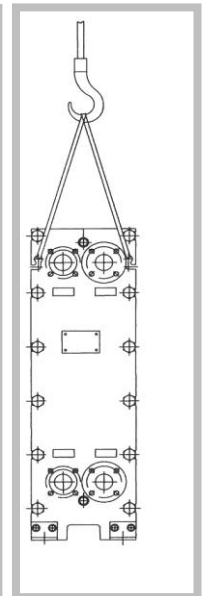

Figure 24

#### 5.4.2 Horizontal delivery - On the head plate

**⚠ DANGER**

**Mortal danger due to tipping over of the PHE**

The PHE can tip over due to its high dead weight.

- Anchor or bolt the PHE firmly at the installation site before you undo the lifting means.

Follow the following instructions:

1. Detach the conveyor belts from the PHE and the pallet.
2. Attach suitable lifting means to the designated suspension eyes of the frame plates (Figure 25). Chain suspensions may not be used. The PHE can be damaged and slip off.
3. Slowly lift the PHE off the pallet with the help of the centre of gravity (Figure 26). Ensure that the lifting means are firm and secure within the suspension eyes.
4. Carefully lower the PHE onto the base of the apparatus (Figure 27).
5. Align the PHE in the desired position and bolt the bases of the apparatus to the floor.
6. Remove the lifting means.
7. Use the order-related documents or the information specified on the name plate to check the tensioning dimension. If these values are not in line with each other, contact thermowave's customer service department.
8. Check whether the screw locking varnish is ruptured [► chapter 4.1.2.2]. In case of damage, contact thermowave's customer service department.

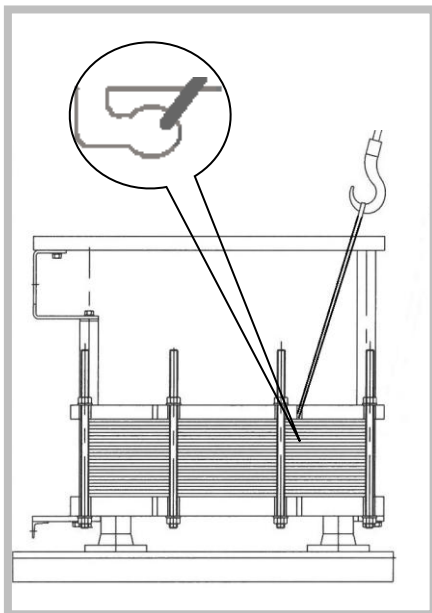

Figure 25

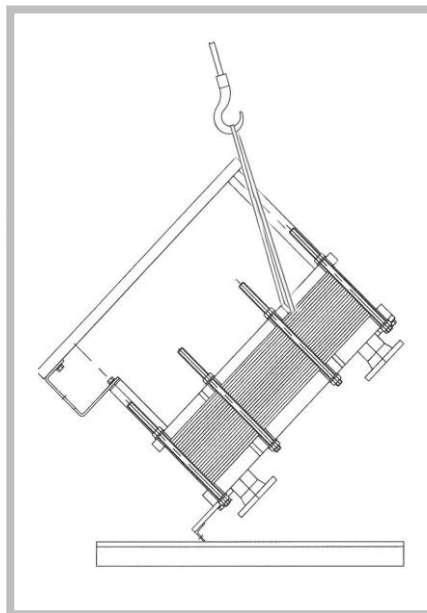

Figure 26

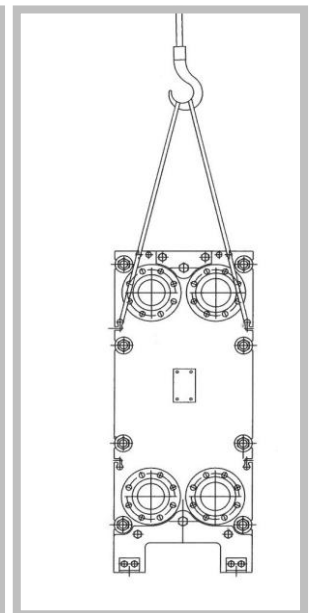

Figure 27

### 5.4.3 Vertical delivery

#### **⚠ DANGER**

##### **Mortal danger due to tipping over of the PHE**

The PHE can tip over due to its high dead weight.

- Anchor or bolt the PHE firmly at the installation site before you undo the lifting means.

##### **Mortal danger due to the PHE falling down**

People can be killed by the high dead weight of the PHE if the lifting means are incorrectly dimensioned and attached.

- Never attach the lifting means to the tensioning screws.
- Never attach the lifting means to the connections or intermediate frames.
- Ensure that the lifting means can bear the weight of the PHE. (Weight declarations in the order-related documents, [▶ chapter 11])

Follow the following instructions:

1. Attach suitable lifting means to the designated suspension eyes of the frame plates (Figure 28). Chain suspensions may not be used. The PHE can be damaged and slip off.
2. Lift the PHE carefully in order to prevent lateral pendular movements.
3. Ensure that the stop angle is at the correct level of ca. 25° (Figure 28).
4. Carefully lower the PHE onto the base of the apparatus.
5. Use the order-related documents or the information specified on the name plate to check the tensioning dimension. If these values are not in line with each other, contact thermowave's customer service department.
6. Check whether the screw locking varnish is ruptured [▶ chapter 4.1.2.2]. In case of damage, contact thermowave's customer service department.

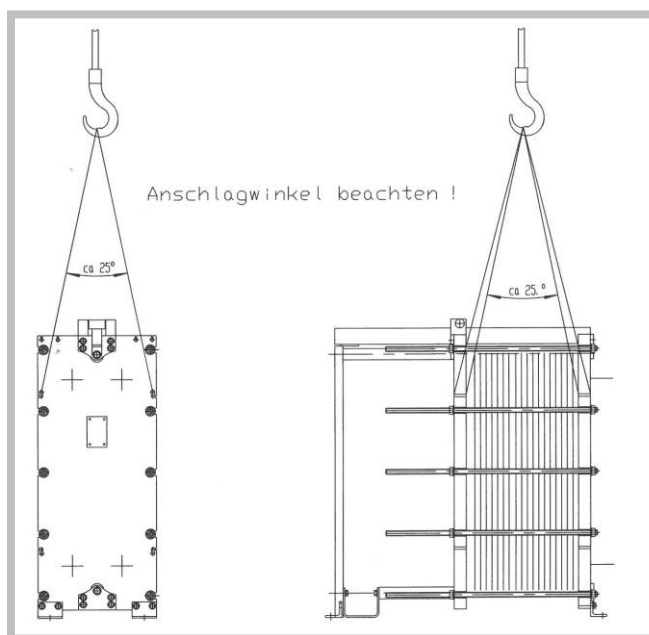

**Figure 28**

#### 5.4.4 Vertical delivery with base of the apparatus

Apparatuses with adjustable apparatus bases are delivered with transport bases. The apparatus bases are included in the delivery. In case of certain apparatuses, the apparatus bases are pre-mounted.

##### **DANGER**

##### **Mortal danger due to tipping over of the PHE**

The PHE can tip over due to its high dead weight.

- Anchor or bolt the PHE firmly at the installation site before you undo the lifting means.

##### **Mortal danger due to the PHE falling down**

People can be killed by the high dead weight of the PHE. If you dimension and attach the lifting means incorrectly,

- Never attach the lifting means to the tensioning screws.
- Never attach the lifting means to the connections or intermediate frames.
- Ensure that the lifting means can bear the weight of the PHE. (Weight declarations in the order-related documents).

Follow the following instructions:

1. Attach suitable lifting means to the designated suspension eyes of the frame plates. Chain suspensions may not be used. The apparatus can be damaged and slip off.
2. Lift the PHE carefully in order to prevent lateral pendular movements.
3. Ensure that the stop angle is at the correct level of ca. 25° (Figure 28).
4. If the bases of the apparatus are not pre-mounted, they must be attached before the system is put down.
5. Carefully lower the PHE onto the base of the apparatus (at the installation site).
6. Use the order-related documents or the information specified on the name plate to check the tensioning dimension. If these values are not in line with each other, contact thermowave's customer service department.
7. Check whether the screw locking varnish is ruptured [► chapter 4.1.2.2]. In case of damage, contact thermowave's customer service department.

## 6 Connection, activation and shutdown

### 6.1 Connection

#### **⚠ DANGER**

##### **Mortal danger due to tipping over of the PHE**

The PHE can tip over due to its high dead weight; this can result in deaths or serious injuries.

- Anchor or bolt the PHE firmly at the installation site before you undo the lifting means.
- The sub-surface of the installation space must be designed for a sufficient load-bearing capacity.
- Ensure secure fixing if the system is to be installed on frames, platforms or floors. The dimension declarations can be found in the order-related documents [▶ chapter 11].

Follow the following instructions:

1. Ensure that there is enough space around the PHE for maintenance and installation activities. More specific information can be found in the diagram in the annexe [▶ chapter 11]. There may be no fixtures between the frame cover and the support.
2. Ensure that the pipes at the frame cover are flexible, so that it will be possible to adjust the tensioning dimension.
3. Any welding at the PHE is prohibited. In case any welding needs to be done at the plant, no electricity shall pass through the PHE.
4. Use suitable connection means to bolt the angle brackets of the frames to the sub-surface/steel structure.
5. Information regarding the constructional design of the connections can be found in the order-related diagram [▶ chapter 11] in the annexe.

#### **NOTICE**

##### **Damage to the pipe connections and PHE due to excessively large connector forces and moments.**

The pipe connections and/or the PHE can be damaged if excessively large forces and moments are transferred to the connections of the PHE via the pipes.

- When the pipes are being installed, it should be ensured that no forces and moments act upon the connections of the PHE.
- If necessary, the inlet and outlet pipes must be propped with pipe holders.

Stud bolts	Average bolting torque for stud bolts / nuts
M 12	20 Nm
M 16	40 Nm
M 20	70 Nm
M 24	110 Nm

Table 1

##### **Ensure that the PHE is not damaged.**

- A protective cover should be provided in case of outdoor installation.

## 6.2 Activation

### **⚠ WARNING**

#### **Risk of injury due to dangerous flow mediums.**

If you are operating the PHE in conjunction with dangerous flow mediums (explosive, inflammable, corrosive, poisonous, high pressure, very hot, very cold etc.), you should ensure that the following safety devices are attached. Be mindful of the applicable regulations and standards associated with the mediums that are being used [► Chapter 11.2] Technical data sheet or the name plate.

- Collecting tray – Explosive, inflammable, corrosive, poisonous, harmful to the environment
- Safety plate – Explosive, inflammable, high pressure, high temperature, corrosive, poisonous, harmful to the environment
- Ground lug – Explosive, inflammable
- Insulation – High temperature, low temperature
- Warning sign – Explosive, inflammable, corrosive, poisonous, very hot, very cold



- Install a safety plate if dangerous mediums are to be used.
- The tensioning dimension must lie in the range of permissible values, which can be found in the order-related documents [► chapter 11].

The following conditions should be borne in mind during activation:

1. Ensure that the entire PHE has been installed.
2. Ensure that all connections are firmly and tightly linked to the PHE.
3. No sudden pressure and temperature changes may take place in the system in which the PHE has been installed.
4. The PHE may only be operated in conjunction with the permissible pressures, temperatures and mediums (refer to the order-related documents in the annexe). These parameters may only be changed if approval has been obtained from thermowave, otherwise the warranty cannot be honoured.
5. In order to protect the gaskets, the PHE may only be subjected to pressure and temperature in a gradual manner. Temperature changes of up to 1 K/s and pressure change rates of up to 2 bar/s are considered to be harmless. This limitation does not apply to brief process-induced temperature changes, such as those associated with CIP cleaning operations of the plate heat exchanger. thermowave must be consulted in case of other deviations.
6. Slowly open the shut-off devices that are upstream of the PHE before starting the pumps. Excessively fast start-ups can result in abrupt pressure loads, which in turn can lead to leakages and scenarios in which the plates and/or gaskets suffer damage.

### **NOTICE**

#### **Damage to the heat exchanger plates due to excessively high strain**

The plates and/or gaskets can be damaged if the plate packet is strained beneath the specified tensioning dimension. The PHE starts leaking, and mediums can emerge.

- Never undercut the final dimension unless thermowave has been consulted in advance.
- Ensure that the tensioning dimension always lies within the range of permissible values.

## NOTICE

### Environmental damage

- If mediums that can harm the environment are to be used, suitable measures should be implemented in order to protect the environment.

## 6.3 Shutdown

The following conditions should be borne in mind during shutdown:

1. Slowly close the shut-off devices that are upstream of the PHE before deactivating the pumps. Excessively fast deactivations can result in abrupt pressure loads, which in turn can lead to leakages and scenarios in which the plates and/or gaskets suffer damage.
2. The PHE must be at the ambient pressure and the ambient temperature before work is begun.
3. Ensure that no medium can escape during brief downtimes.

## NOTICE

### Warning against corrosion.

During longer downtimes, the mediums in the PHE can cause corrosion.

- Remove the mediums completely.
- Rinse the PHE and the plate packet, and let them dry off properly.
- Use dummy plugs to seal the connections of the PHE, in order to ensure that moisture or dirt cannot get into the apparatus during the downtime.
- Store the PHE at a protected location that is not exposed to dust, contamination and moisture, and do not store it any longer than necessary.

## 6.4 Reactivation after shutdown

**When re-commissioning, be sure to pay attention to the following points:**

1. Perform a visual inspection to check the condition of the PHE.
2. Tension the tensioning screws up to the permissible tensioning dimension. The respective values can be found on the name plate or in the order-related documents.
3. In case of a lack of tightness, the plate packet can be re-tightened up to a level that is 3% above the specified initial dimension. Never tension the PHE beneath the specified final dimension.



thermowave customer service

The customer service department will provide high-quality expert assistance in case of any and all questions and problems.

## 7 Operations

### 7.1 Safety

#### **⚠ WARNING**

##### **Warning against serious injuries due to non-compliance with the permissible pressures, temperatures and mediums.**

Dangerous mediums can escape and cause personal injuries in situations involving high pressures and high or low temperatures.

- Ensure that the PHE is only operated in conjunction with the permissible mediums (refer to the name plate, or the annexe of [▶ chapter 11.2]).
- Ensure that the order-related pressure levels and temperatures are the only ones that are adhered to.

##### **Risk of injury due to cutting, burning, scalding, freezing, breathing difficulties, poisoning and cauterisation in case of work that is done while the system is in operation.**

Touching parts of the PHE can lead to serious injuries.

- Do not touch any parts of the PHE without personal protective equipment.

### 7.2 General

The following should be borne in mind:

1. If it is necessary to change the pressure and temperature levels, such changes should only be made after consulting thermowave. Temperature changes of up to 1 K/s and pressure change rates of up to 2 bar/s are considered to be harmless.
2. A written guarantee regarding the corrosion resistance of heat exchanger plates which has been issued by thermowave for specific applications shall only be applicable under the following prerequisites:
  - a. an informative and current medium analysis is available in writing before the order is placed, and the resistance of the materials has been confirmed in writing for the application in question by thermowave,
  - b. all the mediums that flow through the plate heat exchanger are constantly monitored with regard to corrosion-causing components (refer to DIN 50930, sections 1 - 5), and the medium analysis associated with a. is complied with during this monitoring operation,
  - c. the results of the examination associated with point a. are verified on at least a quarterly basis,
  - d. the plate heat exchanger is demonstrably operated under the specified operating conditions at all times.
3. Suitable measures that correspond to the degree of contamination (particle size, loading or the like) should be implemented in order to provide protection against contamination (e.g. installation of filters, sieves etc.). The plate heat exchangers are not suitable for products associated with a high degree of solid loading. It is therefore necessary to install a suitable sieve or filter upstream of the PHE.
4. In case of steam condensers, a sufficiently-dimensioned condensate removal facility should be provided by the customer.

#### **NOTICE**

##### **Environmental damage**

- If environmentally hazardous mediums are used, suitable measures (e.g. collecting trays, plate covers, insulations) should be implemented in order to protect the environment in case of a leak.

##### **Avoidance of starkly-fluctuating operating conditions**

- Ensure that pressure changes, temperature changes and dynamic loading operations do not take place abruptly (e.g. frequent activation/deactivation of valves and pumps).
- Ensure that the armatures of the pipes that are connected to the PHE are always opened and closed slowly.
- Use a suitable process control arrangement to prevent the abrupt condensation of gases.

## 8 Troubleshooting

### 8.1 Safety

#### **⚠ WARNING**

##### **Risk of personal injury and material damage.**

Promptly notify thermowave's customer service department if faults emerge during operations, maintenance activities and servicing activities.

- Faults may only be rectified by appropriately-trained personnel.

### 8.2 Service address

thermowave's customer service department will always be glad to help you correct faults and avoid inappropriate activities and their consequences.

thermowave Gesellschaft für Wärmetechnik mbH  
Eichenweg 4  
06536 Berga

Tel.: +49 34651 418 9980

Fax: +49 34651 418 9924

[service@thermowave.eu](mailto:service@thermowave.eu)

Office timings:

Mo. - Thu. 0730 to 1600 hours

Fr. 0730 to 1400 hours



### 8.3 Performance loss

Fault/Error message	Possible cause(s)	Remedy
Reduced heat transfer	Contamination of the PHE by foreign objects	Clean heat exchanger plates [► chapter 9.7]
		Check pipes for contamination and clean if necessary
		If necessary, use suitable devices to filter the mediums
	Flow rate too high	Set the PHE to the order-related operating data and get it checked by thermowave if necessary
	Incorrect connections to the pipes	Check connections and set them as per the diagram [► chapter 11.3]
	Accumulation of secondary mediums in the PHE (e.g. oil, uncondensed gases etc.)	Provide a discharge facility for the secondary mediums and get it checked by thermowave's customer service department if necessary
Heightened loss of pressure	Contamination of the PHE by foreign objects	Clean heat exchanger plates [► chapter 9.5]
		Check pipes for contamination and clean if necessary
		If necessary, use suitable devices to filter the mediums
	Incorrect connections to the pipes	Check connections and set them as per the diagram
	Viscosity	Check the viscosity and set it to the order-related operating data, get it checked by thermowave if necessary
	Flow rate too high	Set the PHE to the order-related operating data and get it checked by thermowave if necessary
	Flow obstructed due to incorrect installation of the heat exchanger plates	Use the parts list [► chapter 11.1] to check the installation sequence

#### 8.4 Lack of leak-tightness

Fault/Error message	Possible cause(s)	Remedy
Mediums escape from the plate packet and/or from between the frame and the heat exchanger plates	Excessively high operating pressures	Check the specifications in the name plate and the order-related documents [▶ chapter 11.2]
	Too high/Too low operating temperature	Check the specifications in the name plate and the order-related documents
	Incorrect tensioning dimension	Set the correct tensioning dimension with the help of the name plate or the order-related documents (refer to annexe)
	Incorrect seating of gaskets	Open the PHE and check the gaskets and get the system checked by thermowave if necessary
	Gaskets are contaminated	Open the PHE, clean the gaskets and heat exchanger plates and get the system checked by thermowave if necessary
	Gaskets are defective	Open the PHE and replace the gaskets, get the system checked by thermowave if necessary
Damaged heat exchanger plates	Excessive tightening of the heat exchanger plates	Open the PHE, replace the defective heat exchanger plates, set the correct strain dimension with the help of the name plate or the order-related documents and get the system checked by thermowave if necessary
	Corrosion of the PHE	Consult thermowave
	Excessively high and constantly-changing pressure pulses due to pumps and/or valves	Consult thermowave

## 9 Maintenance, servicing and cleaning

On account of its construction principle, the PHE is less vulnerable to contamination than other heat exchangers, because the turbulences that are prevalent in the plate gaps can, to a large extent, prevent external substances from accumulating.

### 9.1 Safety

#### WARNING

##### Risk of injury

There is a risk of injury when maintenance activities involving the PHE are being carried out.

Be mindful of the following points:

- The PHE must be inoperative
- Empty the PHE, and ensure that the mediums are collected securely.
- Ensure that the PHE is at the ambient pressure and ambient temperature before work is begun.
- If dangerous mediums (corrosive, poisonous, combustible, explosive etc.) are used, there is an acute risk of injury to all the people in the surrounding area. Ensure that the regulations for the mediums are followed.
- Always wear suitable protective equipment (PPE).
- If hot or very cold mediums are used, there is a risk of burning or freezing.

### 9.2 Service address

thermowave Gesellschaft für Wärmetechnik mbH  
Eichenweg 4  
06536 Berga

Tel.: +49 34651 418 9980

Fax: +49 34651 418 9924

service@thermowave.eu

Office timings:

Mo. - Thu. 0730 to 1600 hours

Fr. 0730 to 1400 hours



#### thermowave customer service

The customer service department will provide high-quality expert assistance in case of any and all questions and problems.

### 9.3 Maintenance schedule

Schedule regular maintenance intervals in order to facilitate secure operations.

t = daily, w = weekly, m = monthly, j = half-yearly

Activity	t	w	m	j
Visual inspection		x		
Greasing the tensioning screws/profile support rod				x
Partial cleaning	<b>As required</b>			
External cleaning				x
Corrosion inspection/Repairing paint damage				x

The time-wise specifications constitute a recommendation of the manufacturer.

### 9.4 Servicing work



We recommend that thermowave's customer service department be contacted before the PHE is serviced.

#### 9.4.1 Replacing the gaskets

Information regarding the types of gaskets can be found in the order-related documents. We recommend that all plate gaskets be replaced at the same time. Only use original plate gaskets by thermowave.

##### Clip-on system for gasketed heat exchanger plates and modules

The system guarantees optimal and slip-free seating. This makes it possible to carry out a shock-proof and vibration-proof installation operation by utilising the fastening nipples; gaskets can thus be removed and re-installed.

#### NOTICE

##### Warning against damage to the PHE in case of lack of precisely-fitting sitting of the gaskets.

Incorrectly-installed gaskets can lead to leakages and damage to the PHE.

- Ensure that the gaskets [2] are in the designated slot [5], and that the fastening nipples [4] are in the designated holes [3] of the heat exchanger plate [1] (figures 29 through 31).

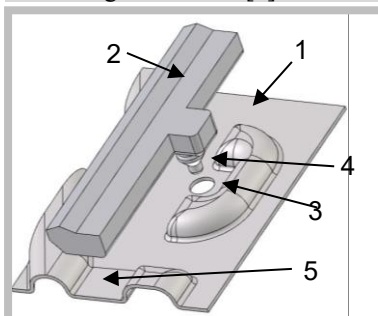

Figure 29: Section of heat exchanger plate [1] and gasket [2]

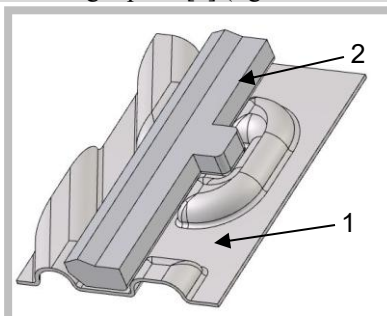

Figure 30: Section of heat exchanger plate [1] with inserted gasket [2]

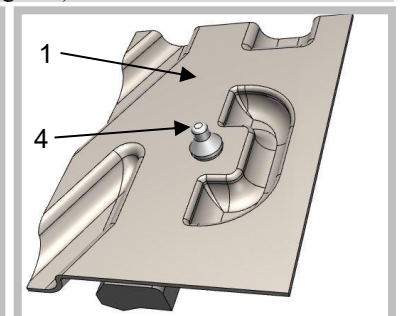

Figure 31: Section of heat exchanger plate [1] with fastening nipple inserted [4] from below

## 9.4.2 Repairing leakages

### **⚠ WARNING**

#### **Risk of injury due to leakages**

Risk of personal injuries. Ensure that leakages are repaired as soon as possible by an expert.

- The PHE should only be reactivated after all the leakages have been repaired.

Follow these instructions if leakages emerge:

1. Deactivate the PHE [▶ chapter 6.3].
2. The PHE must be at the ambient pressure and the ambient temperature before work is begun.
3. Ensure that the pressure-free PHE is not tensioned beyond the final dimension specified on the name plate. Follow the sequence while tightening the tensioning screws [▶ chapter 9.5.2].
4. If leakages persist, contact thermowave's customer service department.

## 9.5 Opening and closing the plate packet

### 9.5.1 Opening the plate packet

#### **NOTICE**

#### **Damages during the warranty period**

The tensioning dimension is precisely adjusted vis-à-vis the operating parameters. Any changes that are to be made during the warranty period should be agreed upon in advance with the manufacturer.

- The manufacturer should be informed before the screw locking varnish [▶ chapter 4.1.2.2] is broken.

### **⚠ WARNING**

#### **Risk of injury**

Opening the PHE gives rise to a risk of injury.

Be mindful of the following points:

- The PHE must be inoperative
- Empty the PHE, and ensure that the mediums are collected securely.
- Ensure that the PHE is at the ambient pressure and ambient temperature before work is begun.
- If dangerous mediums (corrosive, poisonous, combustible, explosive etc.) are used, there is an acute risk of injury to all the people in the surrounding area. Ensure that the regulations for these mediums are followed.
- Always wear suitable protective equipment (PPE).
- If hot or very cold mediums are used, there is a risk of burning or freezing.

#### **Risk of falling in case of stacking of the heat exchanger plates**

Ensure that the heat exchanger plates are not stacked up too high, as they could fall down. You and other people in the area could suffer injuries, and the heat exchanger plates could be damaged.

Never stack up the heat exchanger plates higher than

- 100 heat exchanger plates

Carry out the following work steps:

1. After the PHE has been emptied and the protective covers have been removed, the pipes at the frame cover (if present) should be disassembled in a manner that ensures that there is enough space for the cover to be pushed up to the support.
2. In order to facilitate effortless opening, the support rods and the thread of the tensioning screws should be cleaned.
3. The nuts of the tensioning screws are disengaged in accordance with the sequence depicted in figure 32. In order to facilitate parallel tension release of the plate packet, the nuts should be opened by a **maximum of 2 rotations** per pass. The procedure should be repeated in the specified sequence until it becomes possible to remove the tensioning screws from the clamping slots on the frame plates.



Note down the current tensioning dimension of the plate packet before the PHE is opened, so that you will be able to tension it correctly at the time of reactivation.

	3 tensioning screw pairs	4 tensioning screw pairs	5 tensioning screw pairs	7 tensioning screw pairs	8 tensioning screw pairs	9 tensioning screw pairs
						
Slacken	<b>3 pairs</b>	<b>4 pairs</b>	<b>5 pairs</b>	<b>7 pairs</b>	<b>8 pairs</b>	<b>9 pairs</b>
1st step	3a and 1b	4a and 1b	5a and 1b	7a and 1b	8a and 1b	9a and 1b
2nd step	1a and 3b	1a and 4b	1a and 5b	1a and 7b	1a and 8b	1a and 9b
3rd step	2a and 2b	3a and 2b	4a and 2b	5a and 3b	6a and 3b	2a and 8b
4th step		2a and 3b	2a and 4b	3a and 5b	2a and 7b	5a and 5b
5th step			3a and 3b	6a and 2b	5a and 4b	6a and 4b
6th step				2a and 6b	4a and 5b	7a and 3b
7th step				4a and 4b	7a and 2b	4a and 6b
8th step					3a and 6b	8a and 2b
9th step						3a and 7b

Figure 32: Sequence for opening the tensioning screws

### 9.5.2 Closing the plate packet

1. Check once again whether the plates have been installed in the correct order.
2. Push the moving frame cover as close to the plate packet as possible, and place the tensioning screws in the tensioning screw slots. The seating of the gaskets should be checked once again after light straining. In this regard, the fundamental rule is that the plate packet should have a uniform appearance.
3. The nuts of the tensioning screws are tightened as per the sequence depicted in figure 33. In order to facilitate parallel motion of the plate packet, the nuts should only be tightened by a **maximum of 2 rotations** per pass. The procedure should be repeated in the specified sequence until the specified tensioning dimension (refer to the order-related documents in the annexe) has been attained. Ensure that an authorised person performs a leak test before the plate heat exchanger is reactivated!

	3 tensioning screw pairs	4 tensioning screw pairs	5 tensioning screw pairs	7 tensioning screw pairs	8 tensioning screw pairs	9 tensioning screw pairs
						
Tighten	3 pairs	4 pairs	5 pairs	7 pairs	8 pairs	9 pairs
1st step	2a and 2b	2a and 3b	3a and 3b	4a and 4b	3a and 6b	3a and 7b
2nd step	1a and 3b	3a and 2b	2a and 4b	2a and 6b	7a and 2b	8a and 2b
3rd step	3a and 1b	1a and 4b	4a and 2b	6a and 2b	4a and 5b	4a and 6b
4th step		4a and 1b	1a and 5b	3a and 5b	5a and 4b	7a and 3b
5th step			5a and 1b	5a and 3b	2a and 7b	6a and 4b
6th step				1a and 7b	6a and 3b	5a and 5b
7th step				7a and 1b	1a and 8b	2a and 8b
8th step					8a and 1b	1a and 9b
9th step						9a and 1b

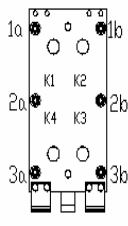
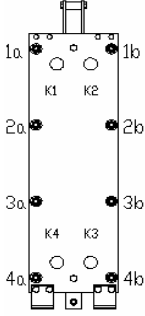
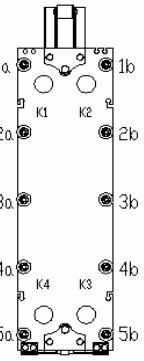
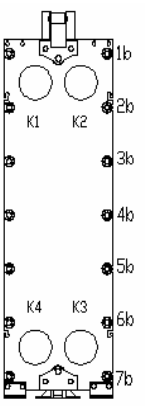
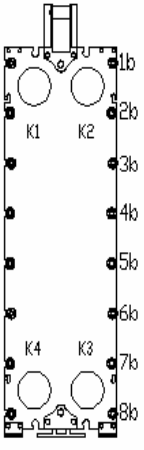
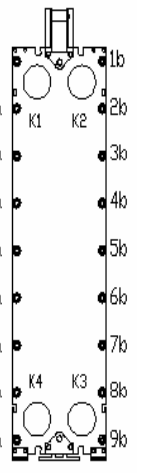
Figure 33: Sequence for closing the tensioning screws

## 9.6 Removal and installation of the plate packet

### **⚠ WARNING**

#### **Risk of injury**

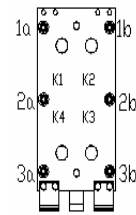
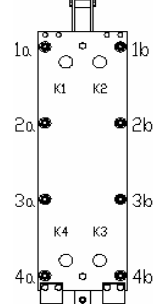
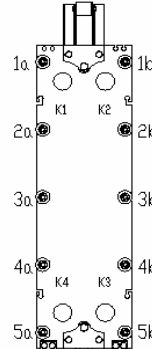
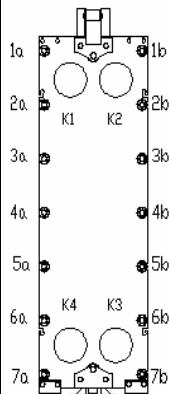
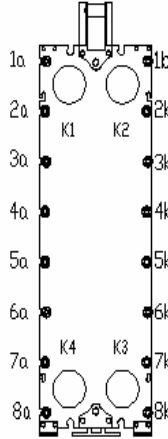
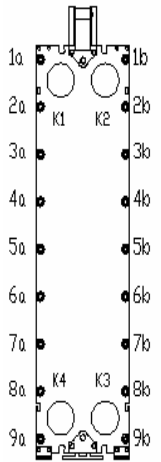
There is a risk of injury while the heat exchanger plates are being installed.

Be mindful of the following points:

- Always wear suitable protective equipment (PPE).

### 9.6.1 Removal of the heat exchanger plates and the modules in case of K, M, T and F (without intermediate frame) frames

1. Open [► chapter 9.5.1] the moving frame cover [2] and push it as close as possible to the support.
2. Guide the heat exchanger plates individually into the support rod area at the support that exhibits a recess [1]. In this area, the heat exchanger plates can, on account of the construction of the lower support rod, be swung out laterally and removed (downwards) from the frame (Figure 34).
3. Deposit the heat exchanger plates in the order in which they were removed! In order to avoid subsequent mistakes, the plates should be numbered consecutively in accordance with their sequence.

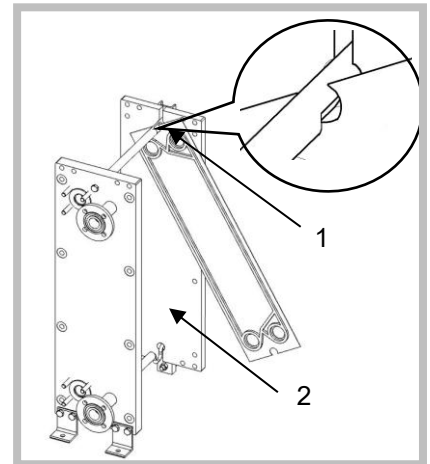

Figure 34

### 9.6.2 Removal of the heat exchanger plates and the modules in case of H frame

1. Open [► chapter 9.5.1] and remove the moving frame cover.
2. A second person should secure the heat exchanger plates against slippage. Push the heat exchanger plate [1] individually out of the support rod (Figure 35).
3. Deposit the plates in the order in which they were removed! In order to avoid subsequent mistakes, the plates should be numbered consecutively in accordance with their sequence.

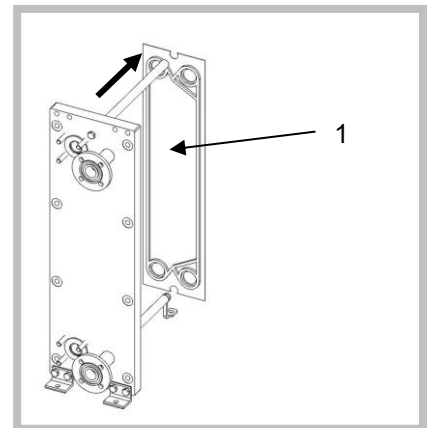

Figure 35

### 9.6.3 Removal of the heat exchanger plates and the modules in case of N and F (with intermediate frame) frames

1. Open [► chapter 9.5.1] the moving frame cover [1] and push it as close as possible to the support.
2. A second person should secure the heat exchanger plates against slippage. Push an individual plate in the direction of the frame cover [1] and bend it diagonally (Figure 36). Swing the heat exchanger plate [2] out laterally.
3. Deposit the plates in the order in which they were removed! In order to avoid subsequent mistakes, the plates should be numbered consecutively in accordance with their sequence.

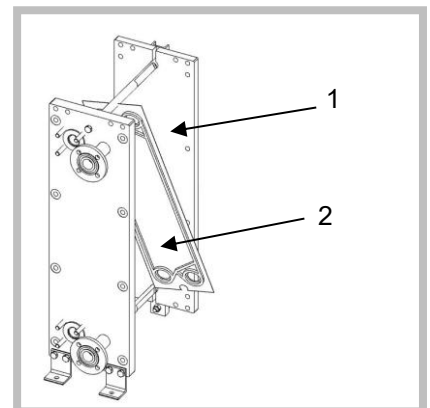

Figure 36

#### 9.6.4 Installation of the heat exchanger plates

##### **⚠ WARNING**

###### **Risk of injury**

There is a risk of injury while the heat exchanger plates are being installed.

Be mindful of the following points:

- Always wear suitable protective equipment (PPE).

Perform the following work steps:

1. Clean the support rod, the frame head and the frame cover.
2. Clean and grease the tensioning screws. Replace them if necessary.
3. The gaskets must fit properly into the heat transfer plates [► chapter 9.4.1]. The surfaces of the plates and gaskets and the sealing surfaces of the connections on the inner sides of the frame head and frame cover must be free of dirt accumulation.
4. The heat exchanger plates are installed in the reverse order of their removal [► chapter 9.6.1].
5. Be mindful of the sequence of the heat exchanger plates as per the parts list [► chapter 11.1]!

#### 9.7 Cleaning

Depending on the degree of contamination and system-technical options, the plate heat exchanger can be cleaned in a variety of ways.

A basic distinction is made between CIP cleaning (in which the apparatus is not opened) and mechanical cleaning (which makes it necessary to open the apparatus).

##### **⚠ WARNING**

###### **Risk of injury due to abrasive cleaning agents**

The use of abrasive cleaning agents gives rise to a risk of poisoning, chemical burns and burning. Ensure the following:

- That the PHE is only reactivated after all the leakages have been repaired.
- That the cleaning agent is used properly and the work steps are performed correctly.
- That suitable protective equipment is worn during cleaning.
- That the cleaning agent has been completely removed from the heat exchanger plates.

##### **NOTICE**

###### **Warning against damages due to incorrect cleaning tools.**

Hard cleaning tools can damage the surface of the heat exchanger plates and lead to corrosion. Damaged heat exchanger plates and gaskets can lead to leakages.

- Never use hard cleaning tools (e.g. metal brushes, steel wool or sandpaper).
- Be very careful while cleaning the system, so that you will not inflict any damage.

### 9.7.1 Cleaning the laser-welded modules

The following should be borne in mind during cleaning:

1. In case of modules, it must be ensured that no cleaning agents and detached pieces of dirt can get into the laser-welded plate gap.
2. Due to design-related factors, a certain amount of residual liquid always remains in the plate gap when the module is exposed to a liquid. This residual liquid can only be removed with a large amount of effort (e.g. vacuum-drying), because the plates are inseparably connected to each other.
3. The laser-welded side should therefore only be subjected to CIP cleaning if the leftover remnants of the cleaning solution are not going to impair subsequent applications. In any event, the system must be rinsed sufficiently after cleaning, and the result of the rinsing procedure must be monitored analytically if necessary.
4. Since the inner side of the module cannot be accessed for mechanical cleaning, it cannot be cleaned manually. When the outer side is being cleaned manually, it must be ensured that the cleaning fluid does not reach the inner side of the module. Suitable tools should be used to close the module openings. A high-pressure cleaner should only be used if the (cleaning) fluid in the laser-welded gap is unobjectionable.



Firmly-adhering dirt should be removed by thermowave's service personnel in accordance with case-by-case specifications. Please direct queries to thermowave's customer service department.

#### NOTICE

##### Damage to the modules

Ensure that no cleaning agents or detached pieces of dirt get into the laser-welded plate gap.

### 9.7.2 CIP cleaning (cleaning in place)

#### NOTICE

##### Damage due to use of the wrong cleaning agent.

The cleaning agent that is to be used may not contain any aggressive components. If pre-fabricated cleaning chemicals are used, the manufacturers' specifications should also be complied with. Such specifications can, for example, relate to the following:

- Concentration of the cleaning agent in the cleaning solution
- Temperature-related specifications corresponding to the application
- Sequence in which different chemicals (basic, acidic) are to be used
- Rinsing and passivation specifications (especially in case of shutdown after cleaning).

##### Damage due to inappropriate prerequisites.

If the plate packet is to be cleaned when it is closed, it is necessary to fulfil the respective system-technical prerequisites, such as:

- The installation of the respective pipe connections, valves, receiver tanks etc. for preparing, storing and guiding the cleaning solution.

##### Damage due to non-compliance with the specified operating temperature.

- The maximum permissible operating temperature specified on the name plate may not be exceeded. This requirement should be fulfilled during steaming (only use saturated steam!) and hot rinsing.

Procedure:

1. In CIP cleaning (cleaning in place), the deposits are first removed from the plates by pumping suitable cleaning agents, and then rinsed out of the apparatus. For successful cleaning, the flow rates of the cleaning solution should exceed the flow rate associated with normal operations (at least 1.5-times the quantity).
2. After the actual cleaning procedure has been completed, the system is rinsed with clear and chemically neutral water in order to remove the cleaning solution from the apparatus. If concentrated cleaning solutions are used, an oxidising acid (e.g. 2% nitric acid) should then, if necessary, be used to carry out a subsequent passivation operation. The system should then be rinsed once again with plenty of water.
3. If evaporators that are on the side of the service medium are to be subjected to CIP cleaning, the cooling agent must be completely sucked out of the apparatus before the apparatus is subjected to a hot cleaning solution or hot water; if this is not done, the plate apparatus can be severely damaged due to the explosive vapour build-up that is to be expected and the associated increase in pressure on the side of the cooling agent.

### 9.7.3 Manual cleaning

Thanks to its flexible construction principle, the plates of the plate heat exchanger can also be cleaned manually with a relatively small amount of effort.

#### NOTICE

##### Damage due to use of the wrong cleaning agent.

The cleaning agent that is to be used may not contain any aggressive components. If pre-fabricated cleaning chemicals are used, the manufacturers' specifications should also be complied with. Such specifications can, for example, relate to the following:

- Concentration of the cleaning agent in the cleaning solution
- Temperature-related specifications corresponding to the application
- Sequence in which different chemicals (basic, acidic) are to be used
- Rinsing and passivation specifications (especially in case of shutdown after cleaning).

To do so, open the plate packet in accordance with the specifications contained in [► chapter 9.5.1].

1. Displace the plates in a manner that ensures that there is enough space between the plates for the cleaning activities and optical inspection.
2. The gaskets should be removed from the heat exchanger plates. It should be ensured that the fastening nipples do not break off.
3. The contamination can be removed by washing the plates with a lot of rinsing fluid and brushing them off (only use soft brushes!).
4. In case of persistent or dried-up deposits, the adherent dirt must first be softened. Towards this end, the plates are first removed [► chapter 9.6.1] and placed in tempered cleaning baths. Please ensure that the plates in the cleaning baths are not damaged by corrosion caused by the cleaning agents that have been used, the adjusted concentration and the temperature. If a high-pressure rinsing device is used to clean the plates, the cleaning jet should strike the plate surface vertically, so that the gaskets will not be damaged.
5. Any gaskets that may have been removed should be re-inserted into the plates after cleaning. In this regard, it must be ensured that there is no contamination between the gasket and the heat exchanger plate. The plates should be reinstalled in accordance with the specifications contained in [► chapter 9.6].
6. The plate packet should be re-closed properly after the cleaning activities have been completed [► chapter 9.5.2].



Firmly-adhering dirt should be removed by thermowave's service personnel in accordance with case-by-case specifications. Please direct queries to thermowave's customer service department.

## 10 Disassembly and disposal

### 10.1 Disassembly

#### **⚠ WARNING**

##### **Risk of injury**

The disassembly of the PHE gives rise to a risk of injury.

Be mindful of the following points:

- The PHE must be inoperative.
- Empty the PHE, and ensure that the mediums are collected securely.
- Ensure that the PHE is at the ambient pressure and ambient temperature before work is begun.
- If dangerous mediums (corrosive, poisonous, combustible, explosive etc.) are used, there is an acute risk of injury to all the people in the surrounding area. Ensure that the regulations for the mediums are followed.
- Always wear suitable protective equipment (PPE).
- If hot or very cold mediums are used, there is a risk of burning or freezing.

### 10.2 Disposal

The PHE must be sent to final recycling at the end of its service life in accordance with the local disposal guidelines.

If requested, thermowave shall dispose of your PHE. The PHE shall be disassembled, transported away and disposed of in a technically correct manner; our employees shall provide these services for a fee.

## **11 Annexe**

### **11.1 Parts list**

### **11.2 Technical data sheet**

### **11.3 Diagram**

### **11.4 Declaration of conformity**



Website



LinkedIn

# EXPERT OF HEAT EXCHANGERS

Makes life fresh



thermowave  
Eichenweg 4  
06536 Berga  
GERMANY

[www.thermowave.eu](http://www.thermowave.eu)

 **thermowave**  
Brand of Heurion Group