



www.thermowave.eu

Power station cooling between minus 56 and plus 34 °C

The Siberian climate represents a particular challenge for refrigeration engineers when it comes to producing power from gas. The Slovakian Elteco company installed Güntner fluid coolers as well as thermowave plate heat exchangers in Siberia to dissipate heat produced by five 2 MW gas generators.

Continental climate zones require reliable plant engineering and solid refrigeration plant components. Temperatures during the Siberian winter can reach minus 56 °C whereas they can climb up to 34 °C in the summer months. Elteco's task was to dissipate the waste heat of five gas generators with a capacity of each 2 MW via fluid coolers in this climate zone. The associated gas is produced near Noyabrsk amidst West Siberian oil fields (Vingapurská region) and processed for power generation. The final customer here is the Mining Company Sibur Tyumen Gaz in Vingapurská, Russia. The electrical energy obtained from the production of power from gas is used locally in the process industry for petroleum and natural gas.

Glycol concentration 67 %

A glycol concentration of at least 67 per cent is required in the refrigeration cycle so that the fluid coolers do not suffer from any damage at the extreme

Overview

Business line:	EPC
Application:	Production of power from gas
Country/Region:	Russia/Vingapurská in Siberia
Fluid:	67 % ethylene glycol
Product:	Güntner fluid cooler S-GFH, thermowave plate heat exchanger EL 500EBGL

thermowave Gesellschaft
für Wärmetechnik mbH
Eichenweg 4
06536 BERGA
GERMANY

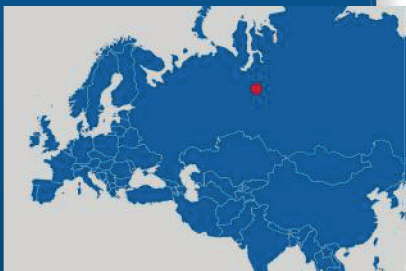



The low-temperature side has a capacity of 178 kW and a refrigerant flow rate of 40.1 m³/h whereas the high-temperature side has 1,020 kW with a coolant flow rate of 73.3 m³/h.

winter conditions prevalent in Siberia. However, the manufacturer of the employed gas generators gives a limit of 50 per cent for the glycol concentration. Another challenge was the restricted roof area of 9,500 x 2,300 mm at the installation site for the air conditioning equipment. Furthermore, the sound level of the refrigerating installation must not exceed 65 dB/7 m.

An efficient solution with two separate coolant circuits was found for Sibur Tyumen Gaz solution: Eight thermowave plate heat exchangers of type EL 500EBGL form an hydraulic interface between the five axial Güntner fluid coolers of type S-GFH and the five 2 MW gas generators.

Special design of the heat exchanger

To cool the motor engine parallel to the flu gas two concurrent cycles with different temperature levels are combined in the customized fluid coolers. The low-temperature side has a capacity of 178 kW and a refrigerant flow rate of 40.1 m³/h whereas the high-temperature side has 1,020 kW with a coolant flow rate of 73.3 m³/h. At external summer temperatures of 34 °C, 190,400 m³/h of air are circulated per cooler.

The heat exchanger of the Güntner GFH fluid cooler is equipped with the tried and tested Güntner floating coil principle. This makes sure that it withstands extreme temperature variations. The fluid coolers' fans are designed for temperatures of up to minus 40 °C as no additional fan power is required for heat dissipation below this temperature.

Thermowave heat exchanger

The heat transfer surface of the gasketed thermowave plate heat exchangers is about 129 m² on the high-temperature side, distributed over 267 plates. The refrigerant of the gas generator is cooled down from 90 to 77 °C while the glycol mixture flow temperature is 74 °C in the plate heat exchanger and the return temperature is 88 °C.

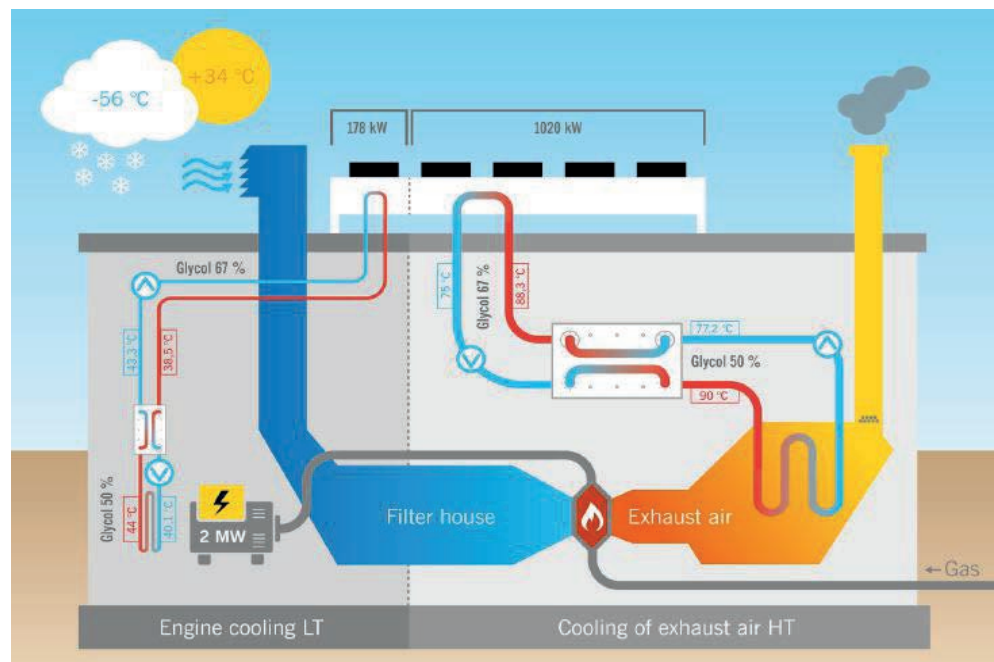

Fig.: gas-fired power plant in Siberia

On the low-temperature side, 101 plates are installed with a surface of about 48 m² cooling down the coolant of the gas generator from 44 to 40 °C. The flow temperature of the glycol mixture in the PHE is 38.5 °C and the return temperature is 43 °C.

Low-temperature side

Capacity:	178 kW
Fluid:	67 % Ethylenglycol
Flow velocity:	40.1 m ³ h ⁻¹
Inlet temperature fluid:	43.3 °C
Return temperature fluid:	38.5 °C
Pressure drop:	22 kPa

High-temperature side

Capacity:	1.020 kW
Fluid:	67 % Ethylenglycol
Flow velocity:	78 m ³ h ⁻¹
Inlet temperature fluid:	88.3 °C
Return temperature fluid:	75.0 °C
Pressure drop:	max. 36 kPa